

COMMONWEALTH DC BRUSHLESS FAN

FP-108EX/DC

172x150x51mm HALLY

DESIGN FEATURES

- *BEARING SYSTEM: BALL BEARING
- *IMPELLER: PLASTIC WITH FIBER GLASS FILLED UL 94V-0
- *HOUSING: DIE CAST ALUMINUM PAINTED BLACK
- *MOTOR: BRUSHLESS DC
- *CONNECTING: WIRE LEADS
- *SPEED: S-1 HIGH SPEED TYPE
S-2 MEDIUM SPEED TYPE
S-3 LOW SPEED TYPE
- *AVAILABLE FG TYPE FOR SPEED SENSOR SIGNAL



DIMENSIONS:MM

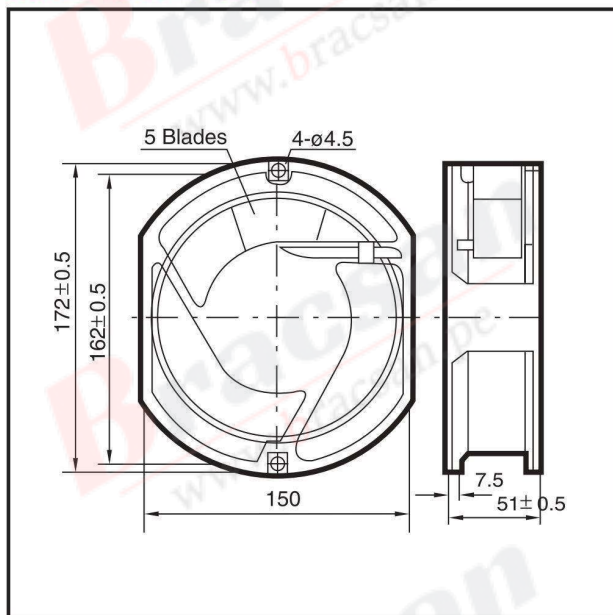

PERFORMANCE

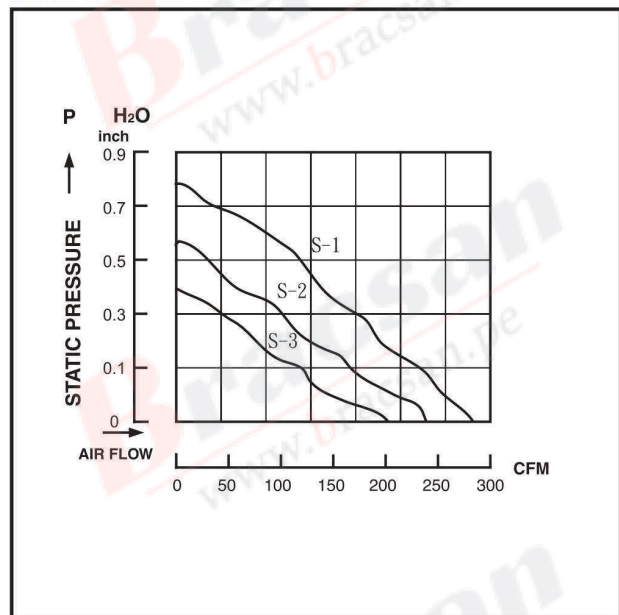

SPECIFICATIONS

Specifications are subject to change without notice

MODEL NO.	VOLTAGE (VDC)	AIR (CFM)	VOLUME (M ³ /MIN)	CURRENT (A)	POWER (W)	SPEED (RPM)	STATIC PRESSURE (INCH-H ₂ O)	NOISE (dBA)
FP-108EX/DC (S-1)	12	270	7.64	2.20	26.40	3150	0.67	60
	24	290	8.23	1.20	28.80	3400	0.78	63
	48	290	8.23	0.73	35.04	3400	0.78	63
FP-108EX/DC (S-2)	12	245	6.94	1.80	21.60	2900	0.55	58
	24	245	6.94	0.77	18.48	2900	0.55	58
	48	245	6.94	0.38	18.24	2900	0.55	58
FP-108EX/DC (S-3)	12	205	5.80	1.10	13.20	2400	0.40	53
	24	205	5.80	0.48	11.52	2400	0.40	53
	48	205	5.80	0.25	12.00	2400	0.40	53